

## Description

Check valve models C\*\*\*\* , Construction is seat type, it allows free flow from Port A to Port B and offers leak free closure in opposite direction

There are two standard mounting types,

1. Line Mounting (Threaded type) Model - C\*T
2. Subplate Mounting type Model - C\*S

**Hydraulic Symbol** A  B

## Technical Specification

Design	:	Seat type valve.
Mounting interface	:	Threaded port - Factory standers or Subplate mounting
Mounting position	:	Optional
Flow Direction	:	Free flow from A to B port, Leak free closure in opposite direction.
Working Pressure	:	315 bar for Port A and B .
Cracking pressure	:	0, 0.5, 1.5, 3 and 5 bar
Flow handling capacity	:	C06-10 l/min, C08-20 l/min, C10-30 l/min, C15-80 l/min, C20- 120 l/min, C25-220 l/min, C30- 280 l/min,
Hydraulic medium	:	Mineral Oil.
Viscosity range	:	10cSt to 380cSt.
Temperature range:	:	-20°C to +80°C
Mass	:	C06T - 0.1 kg, C08T- 0.15 kg, C10T - 0.3 kg, C15T - 0.45 kg, C20T - 0.9 kg, C25T - 2 kg, C30T - 2.4 kg, C06S - 0.3 kg, C10S - 1 kg, C20S - 2.4 kg, C30S - 7.2 kg

## Unit Dimension

Threaded Body Type

Dimensions in mm

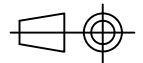
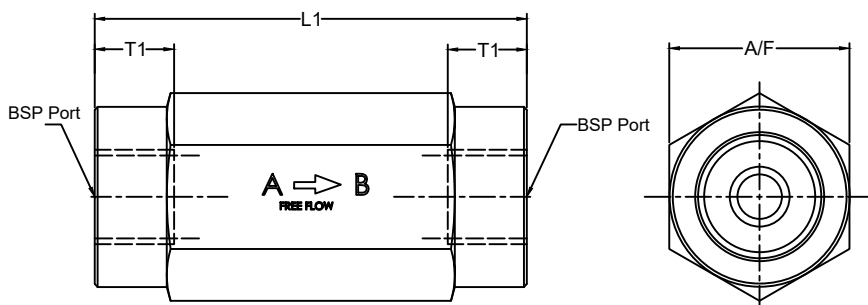

Size	06	08	10	15	20	25	30
BSP Port	G1/4	G3/8	G1/2	G3/4	G1	G1 1/4	G1 1/2
L1	58	58	72	85	98	120	132
T1	12	12	14	16	18	20	22
A/F	19	24	30	36	46	60	65

**Unit Dimension**

Dimensions in mm

Subplate Body Type

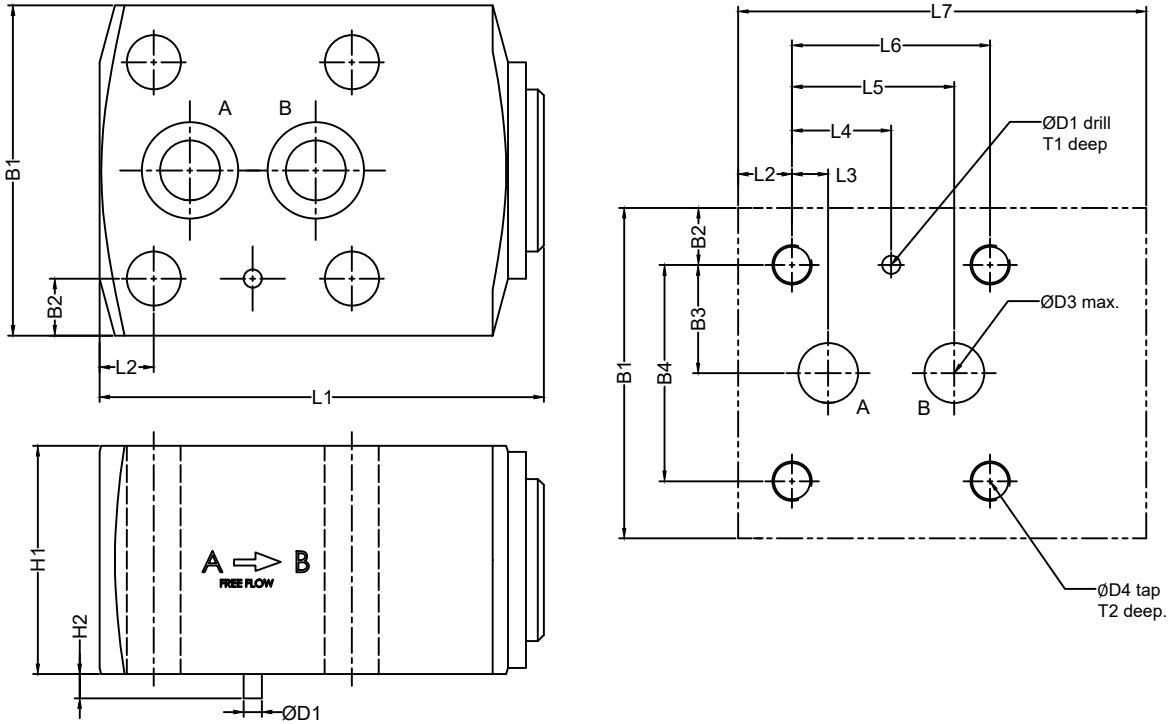
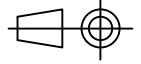

Size	L1	L2	L3	L4	L5	L6	L7	B1	B2	B3	B4	H1	H2	ØD1	ØD2	ØD3	ØD4	T1	T2	Valve Fixing S.H.C (4 nos)	Toque Nm
06	51	7	3	9	15	18	45	37	7.5	11	22	26	3.5	3	4	6	M6	5	12	M6x35L	16
10	74	9	6	16.5	27	33	68	55	9.5	18	36	38	3.5	3	4	11	M8	5	14	M8x50L	39
20	102	10	10	27.5	45	55	95	70	10	25	50	55	5.5	6	7	22	M10	8	19	M10x70L	77
30	139	15	20	42.5	65	85	132	100	12.5	37.5	75	82	5.5	6	7	31	M12	8	22	M12x100L	135

**Ordering Code**

