

Description

Prefill and Exhaust valve models PV** are seat type valves. allowing free flow from its port A to port B and leak free closure in opposite direction. For reverse flow, these valves can be opened by applying pilot pressure to its port X.

The valves are design for the purpose of pre-filling large cylinders during their rapid approach motion. which are actuated mean like a pair of kicker cylinders.

For Connectivity Its A port is machined as per Port dimensions for Flanged connection ISO 6162. The special cavity for the B port helps the user to mount these valves directly on the cylinder.

Hydraulic Symbol

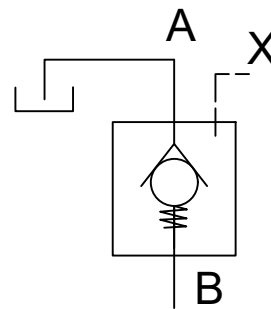

Technical Specification

Design	:	Poppet type, pilot operated
Mounting	:	Inside oil tank mounting or flanged at port A
Mounting position	:	Optional
Flow Direction	:	Free flow from A to B port, Pilot flow from B to A port.
Max operating Pr	:	For Port A 16 bar, and B & X port 315 bar.
Cracking pressure	:	0.2 bar
Pilot pressure required for X port	:	$P_x > 2X P_b - P_a + 8$ bar (to open main poppet of the valve) $P_x > P_b / 5 - (1.2 X P_a) + 8$ bar (to open decom poppet of the valve) $P_x =$ Pilot Pressure, $P_a =$ Pressure at port A (bar), $P_b =$ Pressure at port B (bar)
Pilot volume	:	PV40-10.9cm ³ , PV50-21.3cm ³ , PV63-39cm ³ , PV80-77.6cm ³
Hydraulic medium	:	Mineral Oil.
Viscosity range	:	10cSt to 380cSt.
Temperature range:	:	-20°C to +80°C
Mass	:	PV40 - 7 kg, PV50- 9 kg, PV63 - 18 kg, PV80 - 29 kg
Flow handling capacity	:	

Size	At an average velocity of oil through the valve (m/sec)							
	0.5	1	1.5	2	2.5	3	3.5	4
40	38	76	114	152	190	228	260	304
50	59	118	177	235	295	354	413	472
63	93	186	279	372	465	508	651	744
80	152	304	456	608	760	912	1064	1216

Unit Dimension

Model : PV40 & PV63

Dimensions in mm

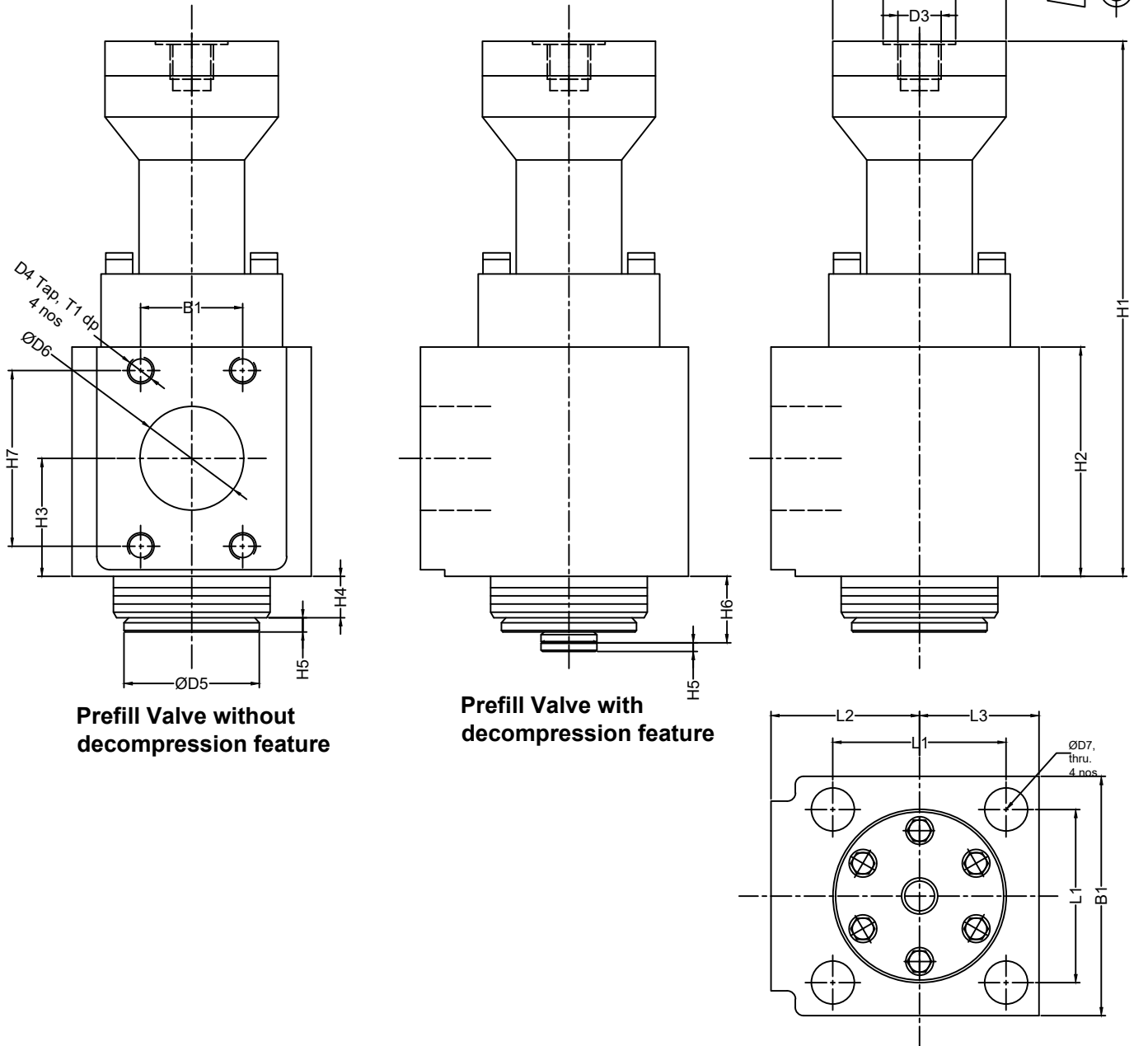

Prefill Valve without decompression feature

Prefill Valve with decompression feature

Table 1

Size	B1	B2	ØD1	ØD2	ØD3	ØD4	ØD5	ØD6	ØD7	H1	H2	H3	H4	H5	H6	H7	L1	L2	L3	T1
40	43	100	54	30	G1/2	M12	52	40	18	220	103	53	26	10	30	78	75	65	50	20
63	62	145	80	30	G1/2	M16	82	63	26	315	139	71.5	34	15	40	106.5	105	90	72.5	25

**Unit Dimension
Model : PV50 & PV80**

Dimensions in mm

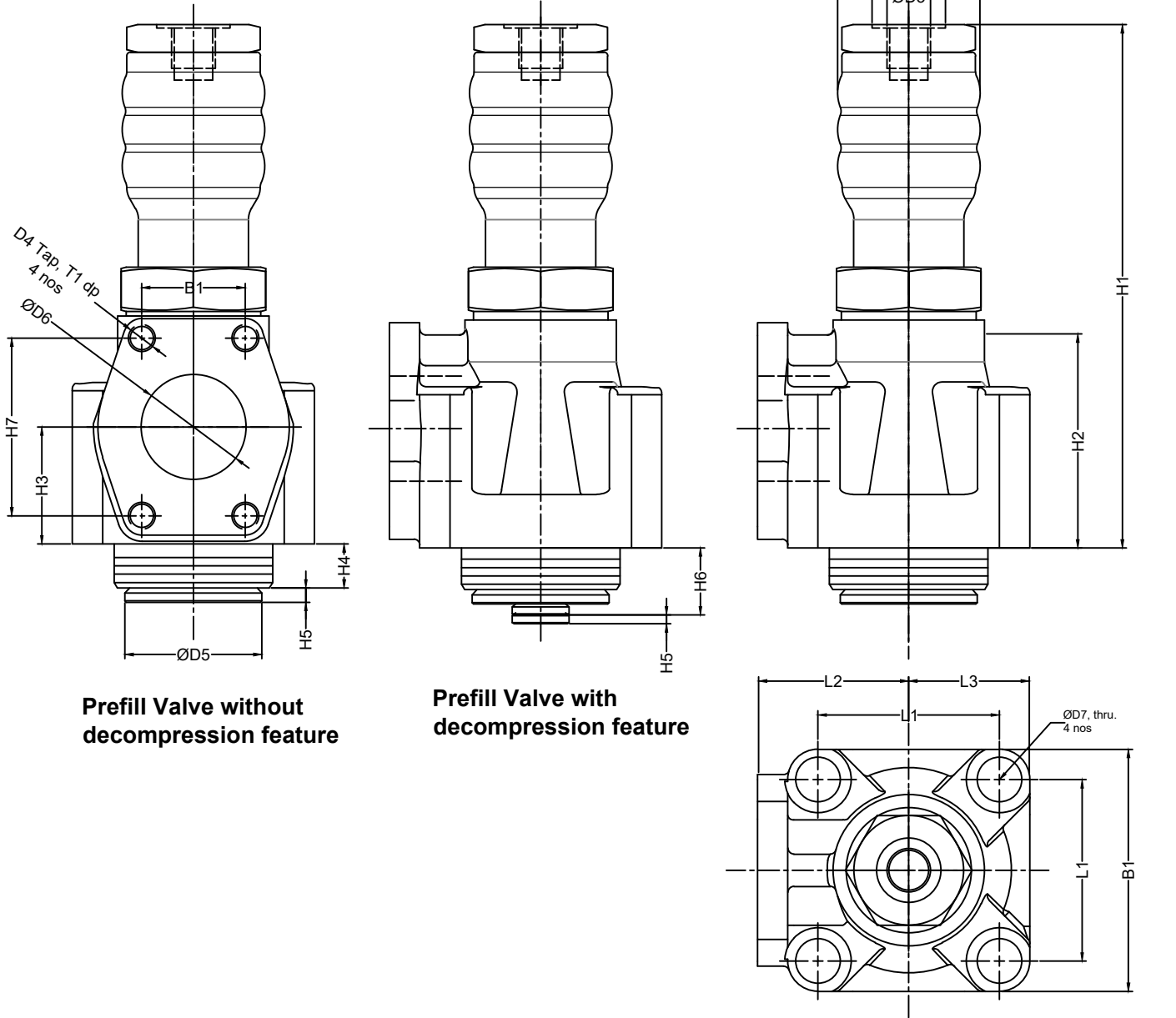

Prefill Valve without decompression feature

Prefill Valve with decompression feature

Table 1

Size	B1	B2	$\varnothing D1$	$\varnothing D2$	$\varnothing D3$	$\varnothing D4$	$\varnothing D5$	$\varnothing D6$	$\varnothing D7$	H1	H2	H3	H4	H5	H6	H7	L1	L2	L3	T1
50	51	120	60	30	G1/2	M12	67	50	22	250	113	58	32	12	37	89	90	75	60	20
80	62	180	92	36	G3/4	M16	102	80	33	397	160	77.5	36	20	43	106.5	130	102	90	25

Unit Dimension

Dimensions in mm

Mounting Cavity Details

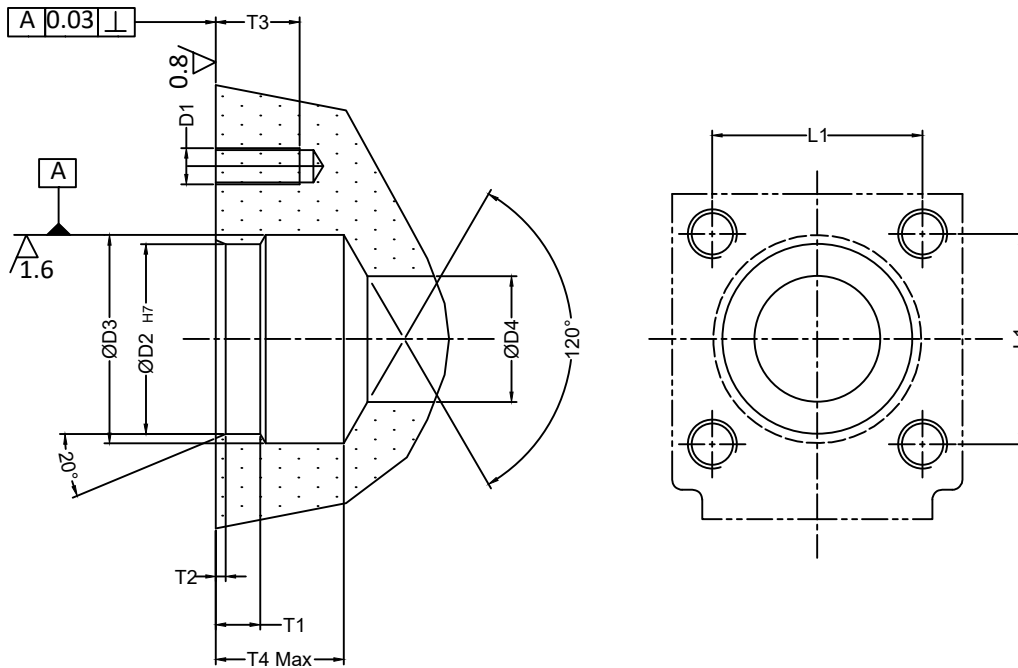
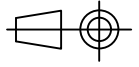

Table 1

Size	ØD1	ØD2	ØD3	ØD4	L1	T1	T2	T3	T4 min	Valve fixing S.H.C. Screw	Tightening torque (Nm)
40	M16	62	66	40	75	20	4	27	46	M16 X 90 L, 4 nos	215
50	M20	80	84	50	90	25	5	32	57	M20 X 110 L, 4 nos	450
63	M24	95	104	63	105	25	5	46	64	M24 X 130 L, 4 nos	1110
80	M30	115	130	80	130	30	5	50	76	M30 X 150 L, 4 nos	2250

Ordering Code

