

Description

Radial piston pump model 11R & 11RE are arrangement with 5, 7 or 9 pumping elements. External mounting type, Face Mounting. valve Control, Fixed delivery, Bi-Directional rotation of shaft. It is extension shaft for through drive with extension bracket assembly for coupling a low pressure pump having standard flanges.

Hydraulic Symbol

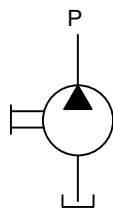

Model : 11R

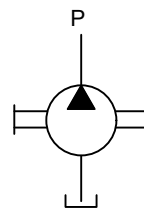

Model : 11RE

Technical Specification

Design	:	11R is a basic radial piston pump, 11RE is a radial piston pump with extension shaft. These pumps are valve controlled and oil immersed.
No. of pumping elements	:	5, 7 or 9
Mounting interface	:	Factory standard, face mounting.
Direction of rotation	:	11R - Bi-directional pump 11RE - Depends upon the direction rotation of pump attached.
Connection	:	Suction port - Sucks oil directly from tank, no suction port Delivery port (P) - G1/2 female
Speed range	:	300 to 2000 rpm
Flow and Pressure	:	Refer Performance table.
Torque limitation	:	Input drive shaft - 220 Nm Extension shaft - 130 Nm
Hydraulic medium	:	Mineral oil
Viscosity range	:	10 cSt to 100 cSt
Temperature range	:	-20°C to +80°C
Fluid cleanliness req.	:	ISO 4406 20/18/15 or better
Mass	:	11R5 - 22 kg, 11RE5 - 22.5 kg, 11R7- 23 kg, 11RE7 - 23.5 kg, 11R9 - 24 kg 11RE9- 24.5 kg.

Dimensions in mm

Unit Dimension

Model : 11R5/7/9

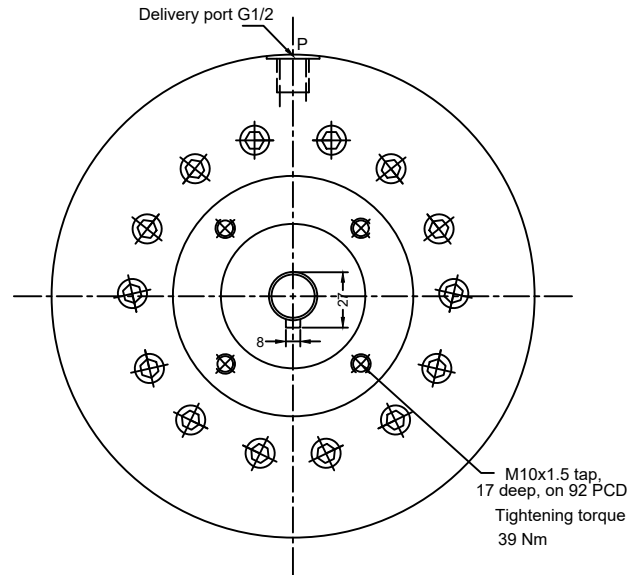
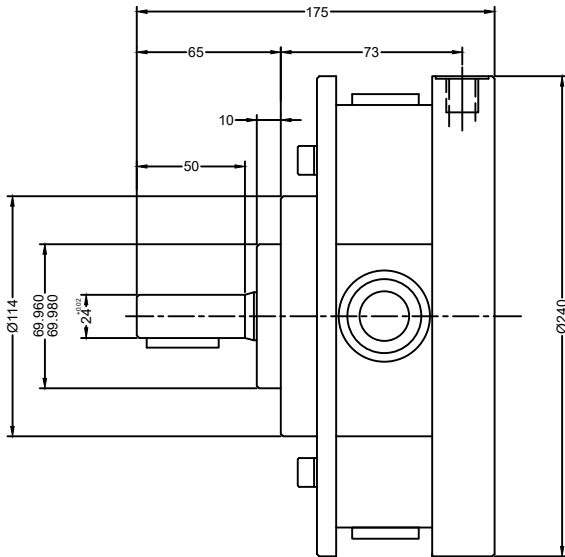
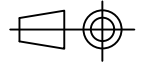

Model : 11RE5/7/9

**Extension Bracket (for through drive)
Dimensions**

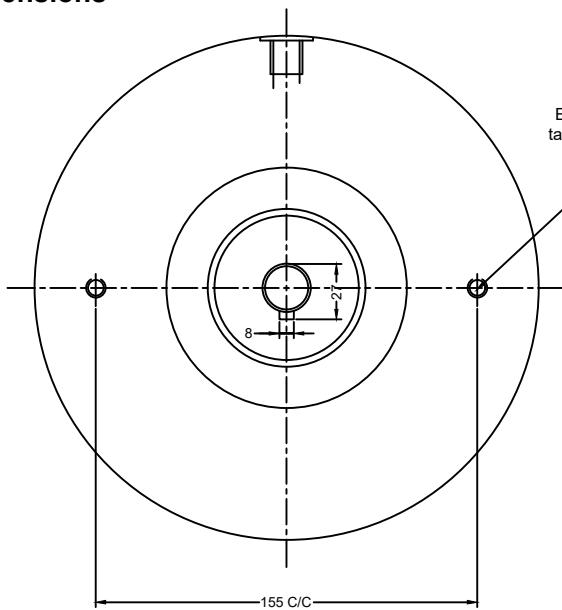

Extension Bracket Mounting
taped holes M16 tap, 20 deep
2 nos.
Tightning torque 77 Nm

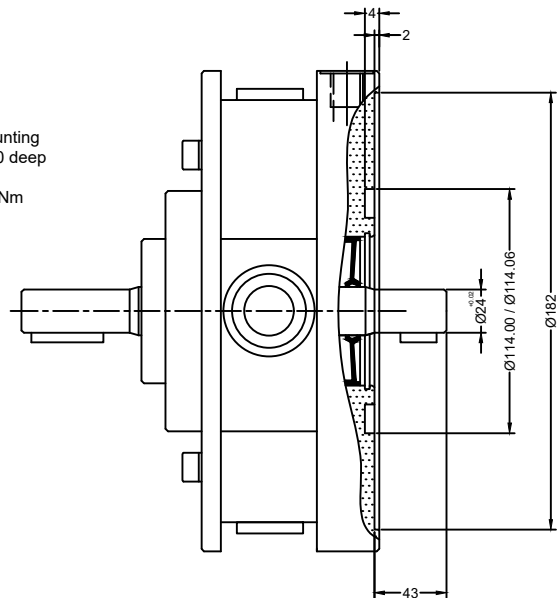

Performance Table

No. of Pumping Elements per section	Element Type	Geometrical displacement in cm ³ /r	Pump Output in l/min at 1450 rpm	Max Operating pressure in bar	Pressure in bar							
					50	100	150	200	250	300	315	400
					Power required for drive the pump in kW							
5	A	7.70	10.5	400	1.09	2.19	3.28	4.38	5.47	6.57	6.89	8.75
7		10.78	14.7		1.53	3.06	4.60	6.13	7.66	9.19	9.65	12.25
9		13.85	18.9		1.97	3.94	5.91	7.88	9.85	11.82	12.41	15.76
5	B	10.05	13.7	315	1.43	2.86	4.29	5.72	7.15	8.57	9.00	
7		14.07	19.2		2.00	4.00	6.00	8.00	10.00	12.00	12.6	
9		18.10	24.7		2.57	5.14	7.72	10.29	12.86	15.43	16.21	
5	C	12.72	17.3	250	1.81	3.62	5.43	7.23	9.04	1kW = 1.3410 hp		
7		17.81	24.3		2.53	5.06	7.60	10.1	12.6			
9		22.90	31.2		3.26	6.51	9.77	13.02	16.28			

Note : Torque limitation - The sum of torque used for the piston pump and torque used at extension shaft end should not exceed 220 Nm (11 kW at 1450 rpm)

Ordering Code

