

Description

Radial piston Double pump model 2R & 2RE are arrangement with 3,5 or 7 pumping elements. in each outlet of the pump. External mounting type, Face Mounting. valve Control, Fixed delivery, Bi-Directional rotation of shaft. It is extension shaft for through drive with extension bracket assembly for coupling a low pressure pump having standard flanges.

Hydraulic Symbol

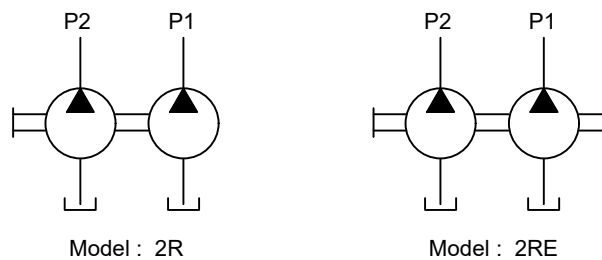

Technical Specification

Design	:	2R is a basic radial piston double pump, 2RE is a radial piston double pump with extension shaft. These pumps are valve controlled and oil immersed.
No. of pumping elements	:	3, 5 or 7, each at P1 & P2 port depending upon flow required.
Mounting interface	:	Factory standard, face mounting.
Direction of rotation	:	2R - Bi-directional pump 2RE - Depends upon the direction rotation of pump attached.
Connection	:	Suction port - Sucks oil directly from tank, no suction port Delivery port (P) - G3/8 female
Speed range	:	300 to 2000 rpm
Flow and Pressure	:	Refer Performance table.
Torque limitation	:	Input drive shaft - 75 Nm Extension shaft - 53 Nm
Hydraulic medium	:	Mineral oil
Viscosity range	:	10 cSt to 100 cSt
Temperature range	:	-20°C to +80°C
Fluid cleanliness req.	:	ISO 4406 20/18/15 or better
Mass	:	2R3 - 9.0 kg, 2RE3 - 9.1 kg, 2R5- 13.3 kg, 2RE5 - 13.5 kg, 2R7- 14.5 kg, 2RE7- 14.7 kg.

Unit Dimension

Model : 2R3

Dimensions in mm

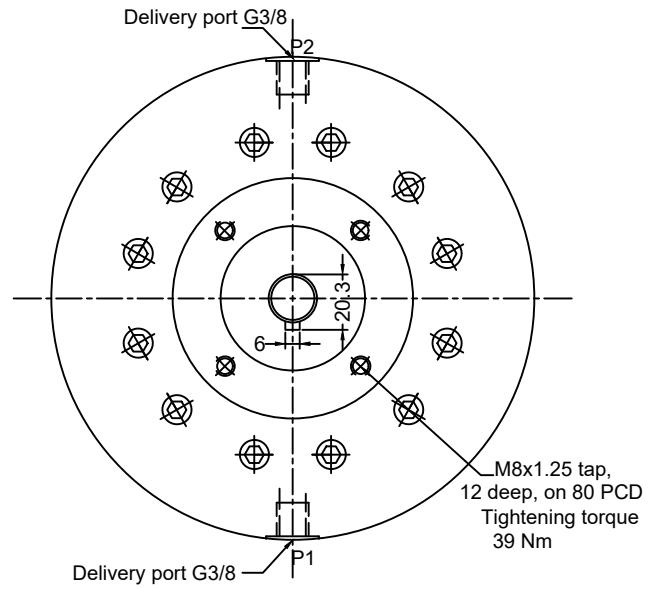
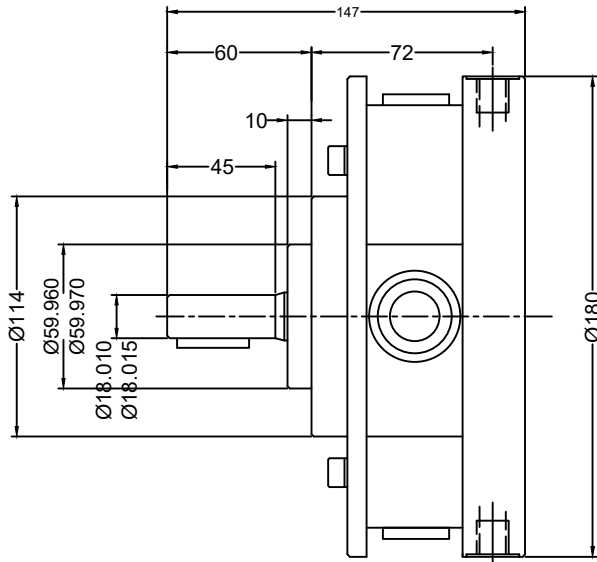
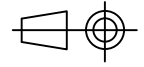

Model : 2RE3

Extension Bracket (for through drive)

Dimensions

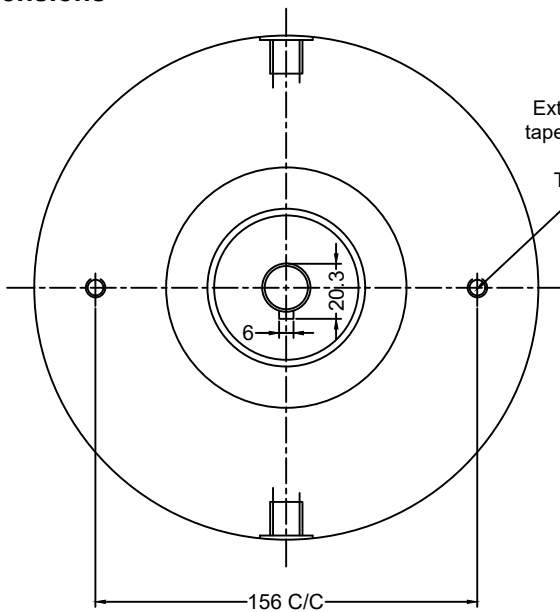

Extension Bracket Mounting
taped holes M10 tap, 17 deep
2 nos.
Tightning torque 77 Nm

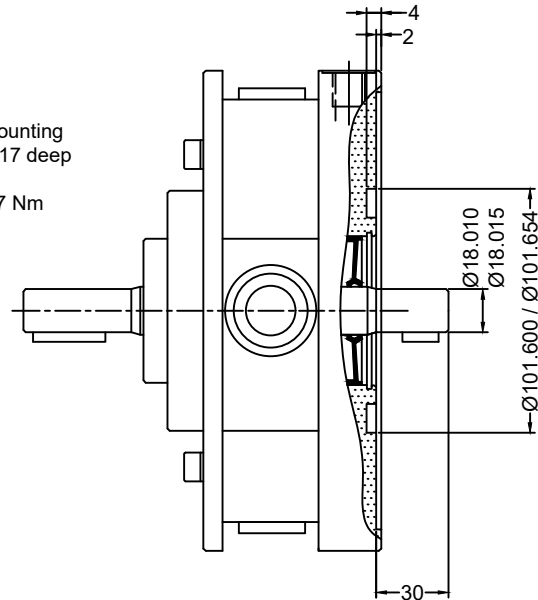

Unit Dimension

Model : 2R5 or 2R7

Dimensions in mm

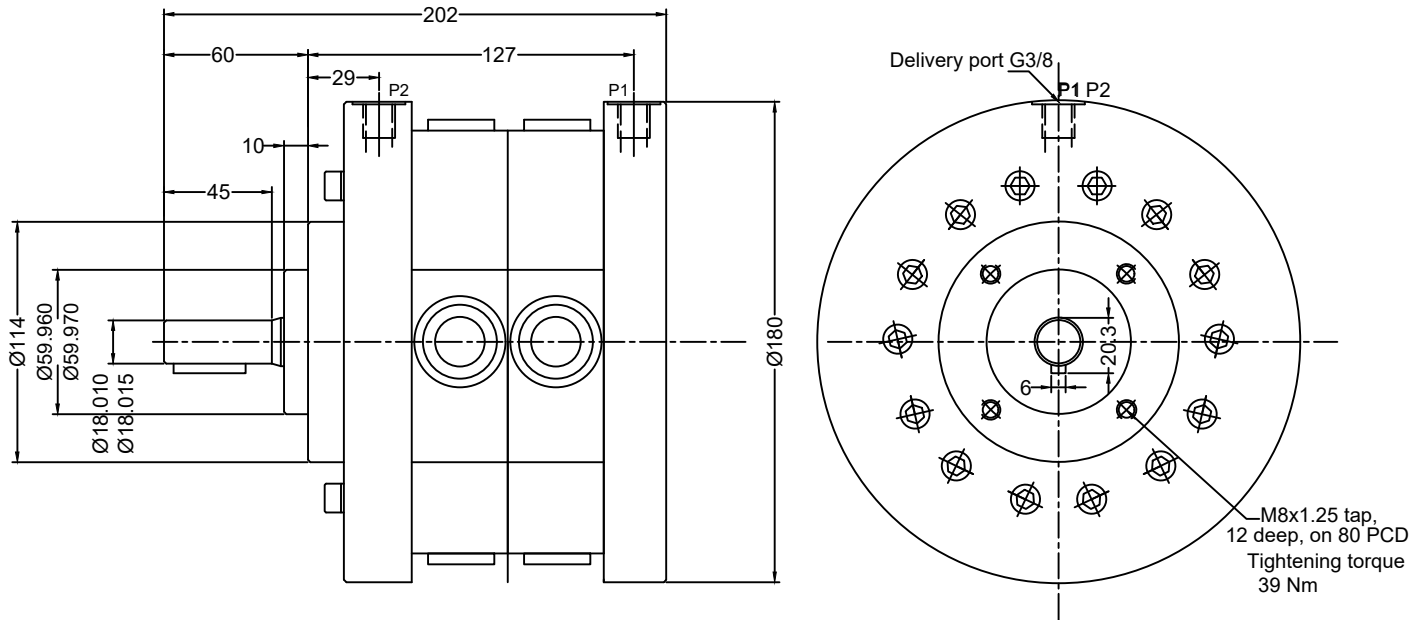
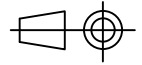

Model : 2RE5 or 2RE7

Extension Bracket (for through drive)

Dimensions

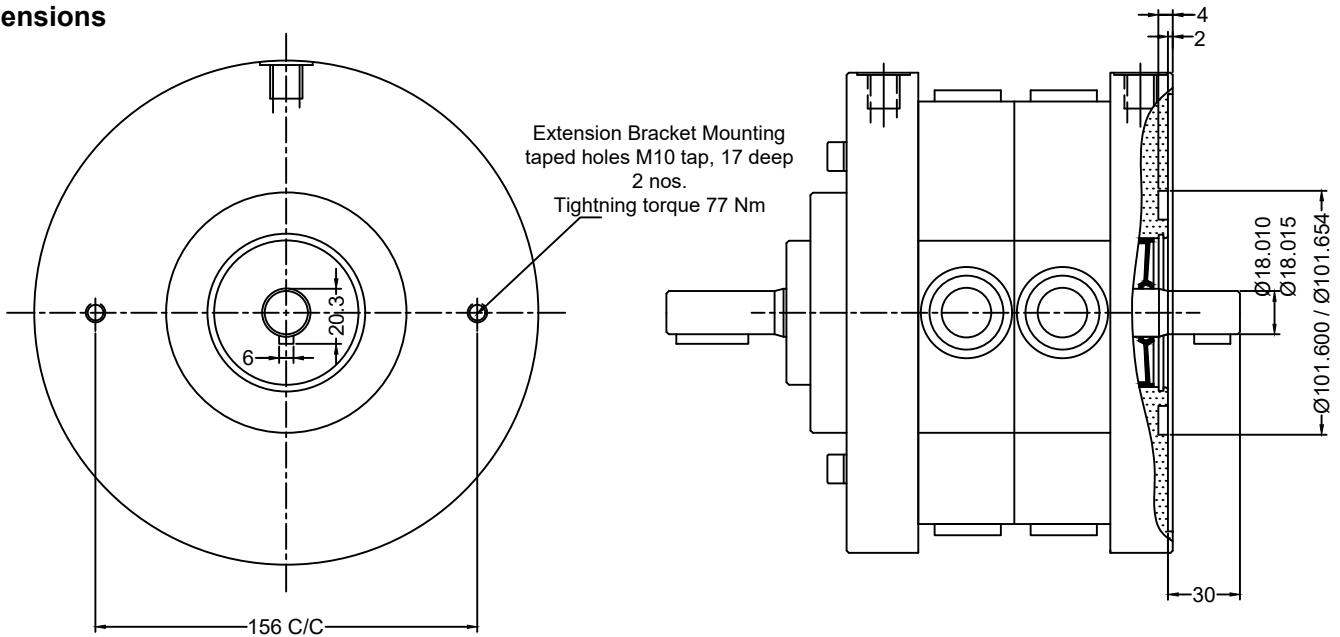

Performance Table

No. of Pumping Elements per section	Element Type	Geometrical displacement in cm ³ /r	Pump Output in l/min at 1450 rpm per section	Max Operating pressure in bar	Pressure in bar													
					50	100	150	200	250	300	350	400	450	500	550	600	650	700
					Power required per section to drive the pump in kW													
3	Z	0.69	0.9	700	0.10	0.19	0.29	0.39	0.48	0.58	0.68	0.77	0.87	0.96	1.06	1.16	1.25	1.35
5		1.15	1.5		0.16	0.32	0.48	0.64	0.80	0.96	1.13	1.29	1.45	1.61	1.77	1.93	2.09	2.25
7		1.61	2.2		0.23	0.45	0.68	0.90	1.13	1.35	1.58	1.80	2.03	2.25	2.48	2.70	2.93	3.15
3	A	1.20	1.6	550	0.17	0.34	0.51	0.69	0.86	1.03	1.20	1.37	1.54	1.71	1.89			
5		2.00	2.7		0.29	0.57	0.86	1.14	1.43	1.71	2.00	2.29	2.57	2.86	3.14			
7		2.80	3.8		0.40	0.80	1.20	1.60	2.00	2.40	2.80	3.20	3.60	4.00	4.40			
3	B	1.89	2.6	450	0.27	0.54	0.80	1.07	1.34	1.61	1.88	2.14	2.41					
5		3.15	4.3		0.45	0.89	1.34	1.89	2.23	2.68	3.13	3.57	4.02					
7		4.41	6.0		0.63	1.25	1.88	2.50	3.13	3.75	4.38	5.00	5.63					
3	C	2.70	3.7	350	0.39	0.77	1.16	1.54	1.93	2.32	2.70							
5		4.50	6.2		0.64	1.29	1.93	2.57	3.22	3.86	4.50							
7		6.30	8.6		0.90	1.80	2.70	3.60	4.50	5.40	6.30							
3	D	3.18	4.3	300	0.45	0.91	1.36	1.81	2.26	2.72								
5		5.30	7.2		0.75	1.51	2.26	3.02	3.77	4.53								
7		7.42	10.1		1.06	2.11	3.17	4.23	5.28	6.34								
3	E	3.69	5.0	250	0.53	1.05	1.58	2.10	2.63									
5		6.15	8.4		0.88	1.75	2.63	3.50	4.38									
7		8.61	11.7		1.23	2.45	3.68	4.90	6.13									
3	F	4.23	5.8	200	0.60	1.21	1.81	2.41										
5		7.05	9.6		1.00	2.01	3.01	4.02										
7		9.87	13.5		1.41	2.81	4.22	5.63										

1kW = 1.3410 hp

Note : Torque limitation - The sum of torque used for the piston pump and torque used at extension shaft end should not exceed 75 Nm (11 kW at 1450 rpm)

Ordering Code

