

Description

Pilot operated check valve modular construction Model CIM 06 and CIM 10, Construction of this valve is modular, seat type, internal pilot operated valve. Provide pressure holding facility on their service port A1 and B1. These valves are also available with pilot check facility on their A or B port, when other port is pressurized, the valve opens and allows free return flow.

Hydraulic Symbol

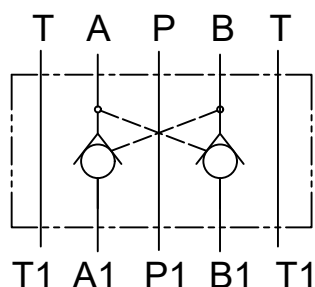

Model : CIMAB**

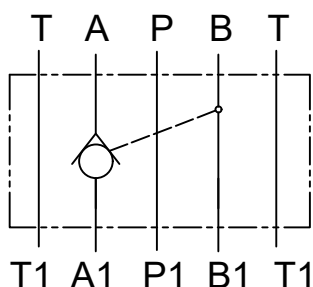

Model : CIMA**

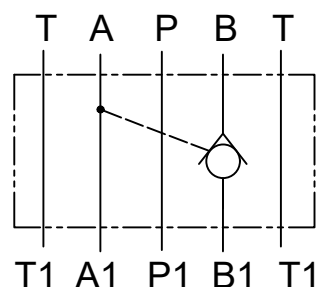

Model : CIMB**

Technical Specification

Design :	Modular Construction, Seat type, Internally pilot operated valve.
Mounting interface :	Subplate mounting modular ISO 4401-AC 05-4-A, IS10187, DIN24340
Mounting position :	Optional
Flow Direction :	Free flow from A to A1, and /or from B to B1 Pilot flow in opposite direction
Working Pressure :	315 bar for all ports .
Cracking pressure :	1, 3 or 5 bar
Area ratios :	CIM06 - Pilot piston : Poppet = 2.6 : 1 CIM10 - Pilot piston : Decom Poppet = 3.5 : 1
Flow handling capacity :	CIM06 - 40 l/min and CIM10 - 80 l/min.
Hydraulic medium :	Mineral Oil.
Viscosity range :	10cSt to 380cSt.
Temperature range:	-20°C to +80°C
Mass :	CIM06AB/A/B - 1 kg, CIM10AB - 2 kg, CIM10A/B - 1.8 kg,

Dimensions in mm

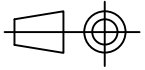

Unit Dimension

Model : CIM06**

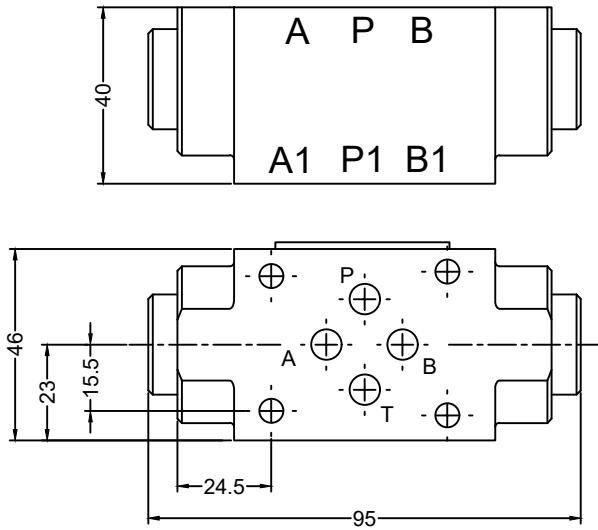

Subplate Mounting Interface CIM06**

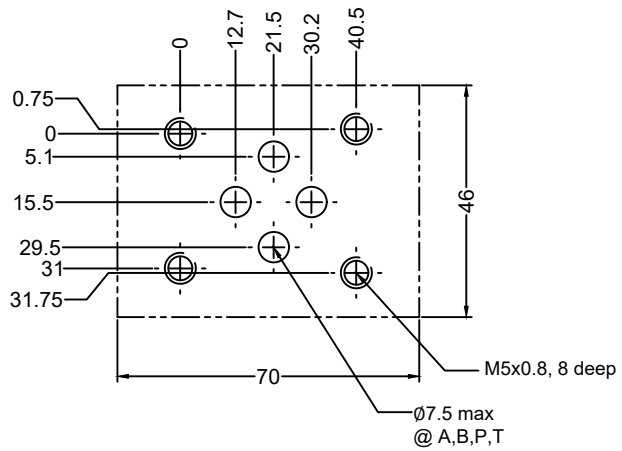

Model : CIM10**

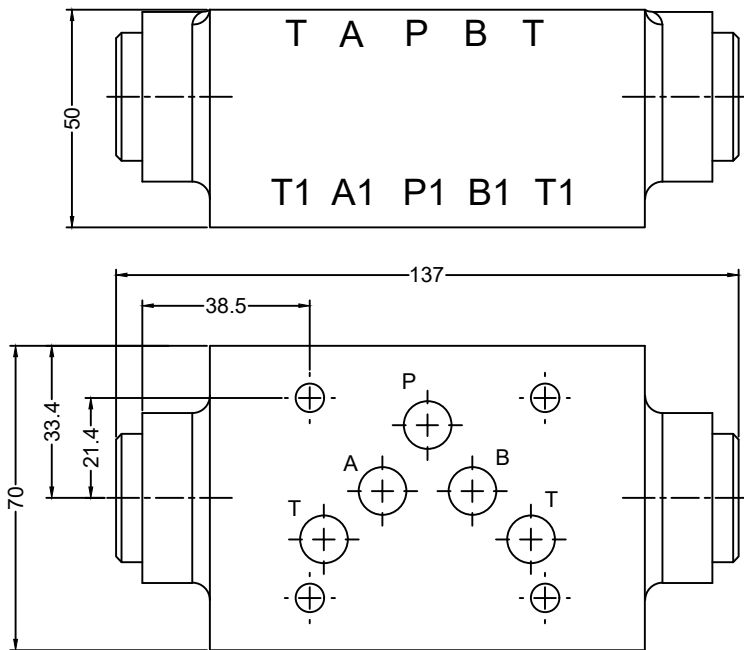

Subplate Mounting Interface CIM10**

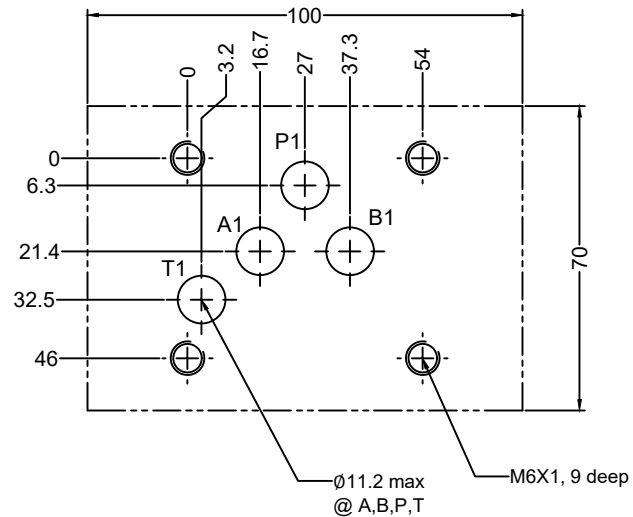

Ordering Code

CIM	10	AB	1	01
-----	----	----	---	----

Pilot Operated Check Valve
Modular Construction

Size 06 or 10

Design code

Pilot optd. check facility	
On A & B ports	AB
On A ports	A
On B ports	B

Cracking Pressure (bar)	
1	1.0 bar
3	3.0 bar
5	5.0 bar